



# Diamond Tub & Showers Spec Sheet

Model: TO2 663824

Description: 2 Piece Rectangular Free Standing Tub

## Specifications

Model #	Material	Wall Finish	Pieces	Drain	Total Height	Net Weight Lbs.
TO2 663824	Fiberglass/ Gelcoat	Smooth	2	End	23 7/8"	

## Sump Data

Top of Drain to Bottom of Overflow	Capacity to Overflow Gallons	Top Dimensions		Bottom Dimensions	
		Length	Width	Length	Width
18 1/4"	97.0	59 5/8"	33 7/8"	34 1/4"	21 7/8"

## Framing Dimensions

A	B	C	D
NA	NA	NA	NA

## Enclosure Opening

Length	Width
NA	NA

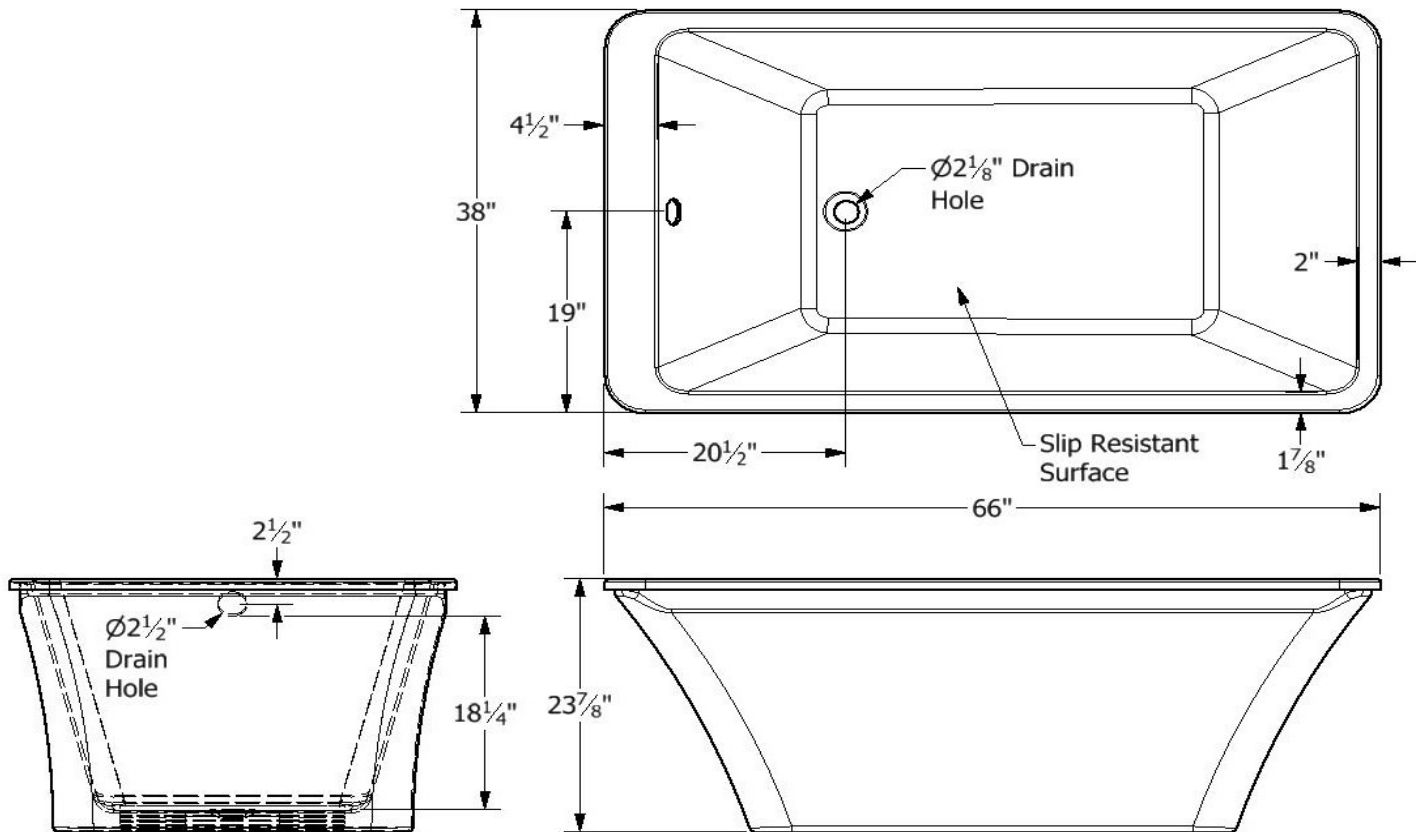

Certified to conform to ANSI Z124.1 and ASTM E- 162 Flame Spread Rating 200 or less and is under a program of factory inspection.

Manufactured by Front Line Mfg., Inc. Warsaw, IN



11/7/19